

VFD-L Series Instruction Sheet

1 Preface

Thank you for choosing DELTA's VFD-L series AC Drive. The VFD-L series is manufactured using high-quality components, material and incorporating the latest microprocessor technology available.

This manual will help in the installation, parameter setting, troubleshooting, and daily maintenance of the AC motor drive. To guarantee safe operation of the equipment, read the following safety guidelines before connecting power to the AC motor drive. Keep this operating manual handy and distribute to all users for reference.

Important Notes:

- DANGER** AC input power must be disconnected before any maintenance. Do not connect or disconnect wires while power is applied to the circuit. Only qualified technicians should perform maintenance on the VFD-L.
- A charge may still remain in the DC-link capacitor with hazardous voltages even after the power has been turned off. To avoid personal injury, do not remove the cover of the AC drive until all "DISPLAY LED" lights on the digital keypad are off. Please note that there are live components exposed when the AC drive is open. Be careful to not touch these live parts.
- The AC drive may be destroyed beyond repair if power is misapplied to the input/output terminals. Never connect the AC drive output terminals U/T1, V/T2, W/T3 directly to the AC main circuit power supply.
- There are highly sensitive MOS components on the printed circuit boards. These components are especially sensitive to static electricity. To avoid damaging these components, do not touch the circuit boards with metal objects or your bare hands.
- Ground the VFD-L using the ground terminal. The grounding method must comply with the laws of the country where the AC drive is to be installed.

2 Receiving and Inspection

This VFD-L AC drive has gone through rigorous quality control tests at the factory before shipment. Since many things may happen during shipping, please check for the following after receiving the AC motor drive.

- Inspect the unit to insure it was not damaged during shipment.
- Make sure that the part number indicated on the nameplate corresponds with the part number of your order.

Nameplate Information: Example of 1HP230V

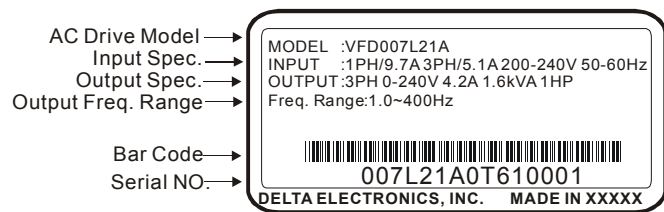

Model Explanation

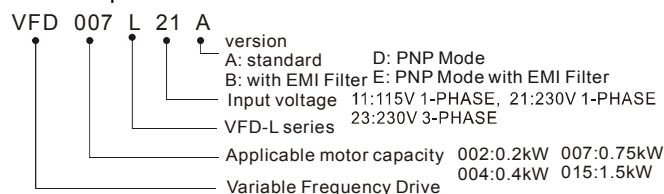

Serial Number Explanation

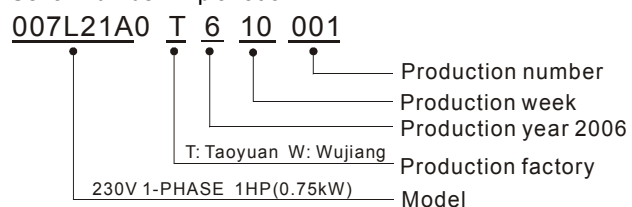

If there is any nameplate information not corresponding to your purchase order or any problem, please contact your distributor.

Dimension

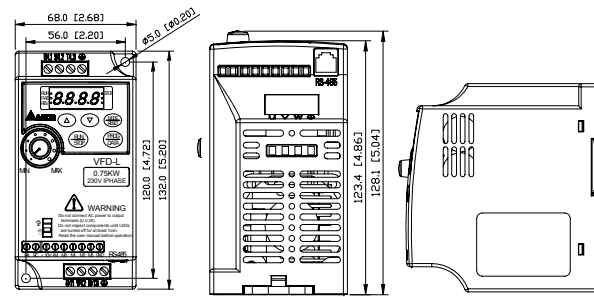

3 Wiring

Basic Wiring Diagram

Users must connect wiring according to the circuit diagram shown below. Please follow all National and State wiring codes, when wiring the VFD-L.

Figure 1 for models of VFD-L series VFD002L11A, VFD002L11B, VFD002L21A, VFD002L21B, VFD004L11A, VFD004L11B, VFD004L21A, VFD004L21B, VFD007L21A, VFD007L21B, VFD015L23A

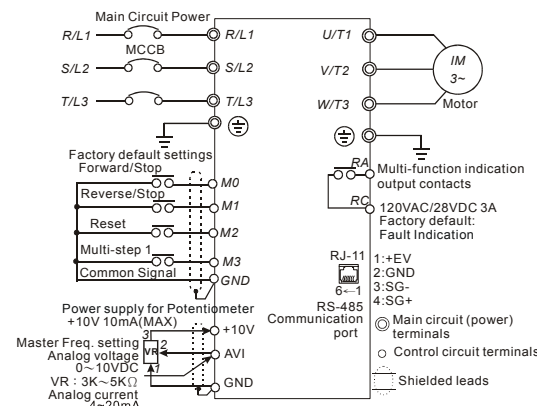

NOTE: Do not plug in a Modem or telephone line to the RS-485 communication port, permanent damage may result. Terminals 1 & 2 are the power source for the optional copy keypad and should not be used while using RS-485 communication.

- *If the AC Drive model is VFD002L11A/B, VFD004L11A/B, VFD002L21B, VFD004L21B or VFD007L21B, please use power terminals R/L1 and S/L2.
- *If the AC Drive model is VFD002L21A, VFD004L21A or VFD007L21A, 1-phase/3 phase power may be used on R/L1, S/L2, T/L3. When VFD002L21A/VFD004L21A or VFD007L21A use 1-phase power, please select any two of the three input terminals R/L1, S/L2, T/L3.
- *If the AC Drive model is VFD015L23A, single phase power is not allowed.

Figure 2 for models of VFD-L series VFD004L21D, VFD004L21E, VFD007L21D, VFD007L21E

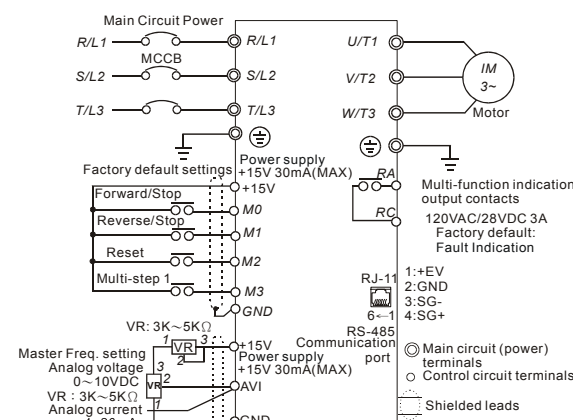

NOTE: Do not plug in a Modem or telephone line to the RS-485 communication port, permanent damage may result. Terminals 1 & 2 are the power source for the optional copy keypad and should not be used while using RS-485 communication.

- *If the AC Drive model is VFD004L21E, VFD007L21E, please use power terminals R/L1 and S/L2.
- *If the AC Drive model is VFD004L21D, VFD007L21D, 1-phase/3 phase power may be used on R/L1, S/L2, T/L3. When VFD004L21D/VFD007L21D use 1-phase power, please select any two of the three input terminals R/L1, S/L2, T/L3.

Wiring for NPN mode and PNP mode

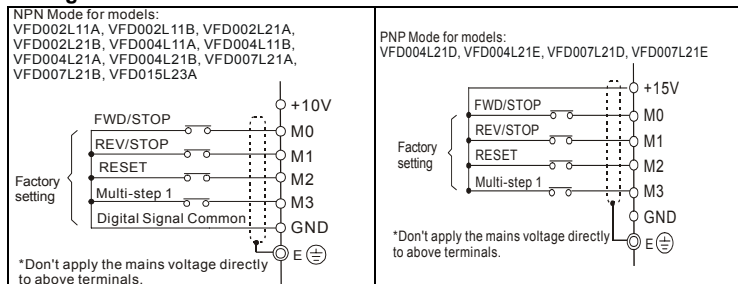

*Don't apply the mains voltage directly to above terminals.

Main circuit wiring

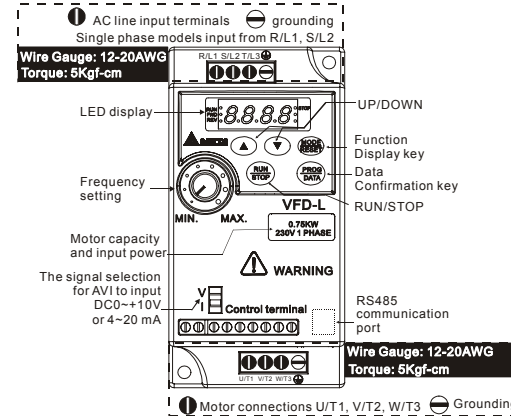

Control circuit wiring

Figure 3 for models: VFD002L11A, VFD002L11B, VFD002L21A, VFD002L21B, VFD004L11A, VFD004L11B, VFD004L21A, VFD004L21B, VFD007L21A, VFD007L21B, VFD015L23A

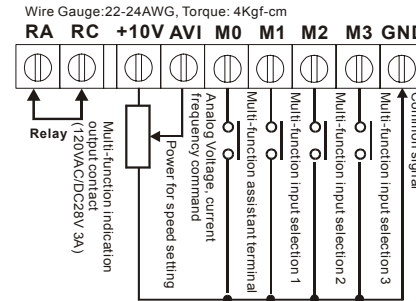
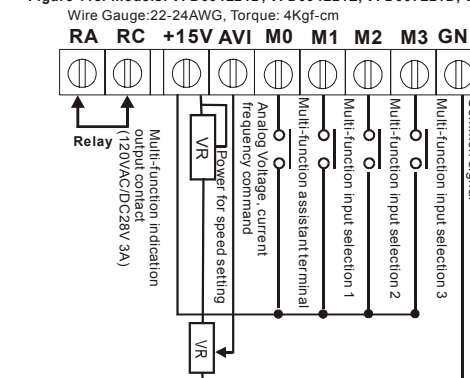

Figure 4 for models: VFD004L21D, VFD004L21E, VFD007L21D, VFD007L21E



Wiring Notes: PLEASE READ PRIOR TO INSTALLATION.

- Do not connect the AC input to any of the U/T1, V/T2, W/T3 terminals, as it will damage the AC drive.
- During installation, follow all national and local electrical, construction, and safety codes for the country the drive is to be installed in.
- Ensure the appropriate protective devices (circuit breaker or fuses) are connected between the power supply and AC drive.
- Make sure that the leads are connected correctly and the AC drive is properly grounded. (Ground resistance should not exceed 0.1 Ω.)
- Use ground leads that comply with AWG/MCM standards and keep them as short as possible.
- Multiple VFD-L units can be installed in one location. All the units should be grounded directly to a common ground terminal. The VFD-L ground terminals may also be connected in parallel, as shown in the figure below. Ensure there are no ground loops.
- When the AC drive output terminals U/T1, V/T2, and W/T3 are connected to the motor terminals U, V, and W, respectively, the motor will rotate counterclockwise (as viewed from the shaft ends of the motor) when a forward operation command is received. To reverse the direction of motor rotation, switch over any of the two motor leads.
- Make sure that the power is capable of supplying the correct voltage and required current to the AC drive.
- Do not attach or remove wiring when power is applied to the AC drive.
- Do not monitor the signals on the circuit board while the AC drive is in operation.
- Route the power and control wires separately, or orthogonal to each other.
- If a filter is required for reducing EMI (Electro-Magnetic Interference), install it as close as possible to AC drive. EMI can also be reduced by lowering the Carrier Frequency.

- If the AC drive is installed in the place where a load reactor is needed, install the filter close to U/T1, V/T2, W/T3 side of AC drive. Do not use a Capacitor or L-C Filter (Inductance-Capacitance) or R-C Filter (Resistance-Capacitance).
- When using a general GFCI (Ground Fault Circuit Interrupter), select a current sensor with sensitivity of 200mA or above, and not less than 0.1-second operation time to avoid nuisance tripping. For the specific GFCI of the AC motor drive, please select a current sensor with sensitivity of 30mA or above.

4 Summary of Parameters

Group 0: User Parameters / The parameter may be set during operation.

Pr.	Functions	Settings	Factory Setting
0-00	Identity code of drive (Read only)	d1: 40W d2: 100W d3: 200W d4: 400W d5: 750W d6: 1.5KW	
0-01	Rated current display (Read only)	40W: d0.4A 100W: d0.8A 200W: d1.6A 400W: d2.5A 750W: d4.2A 1.5K: d7.0A	
0-02	Parameter reset	d10: Reset Parameters to Factory Setting	d0
0-03	Start-up display of AC drive	d0: F (Frequency command) d1: H (output frequency) d2: U (user-defined unit) d3: A (output current)	d0
0-04	User-defined Unit	d0: Display User-Defined Unit (u) d1: Display Counter Value (C) d2: Display Process Operation (1=tt) (Display the current speed's step and the rest time for this step speed) d3: Display DC-BUS voltage (U) d4: Display output voltage (E)	d0
0-05	User-defined coefficient K	d0.1 ~ d160	d1.0
0-06	Software version	Read only	##
0-07	Password input	d0 ~ d999	d0
0-08	Password configuration	d0 ~ d999	d0

Group 1: Basic Parameters

Pr.	Functions	Settings	Factory Setting
1-00	Maximum operation Freq.	d50.0 ~ d400Hz	d60.0
1-01	Maximum setting Freq.	d10.0 ~ d400Hz	d60.0
1-02	Maximum output voltage	d2.0 ~ d255V	d220
1-03	Mid-point freq.	d1.0 ~ d400Hz	d1.0
1-04	Mid-point voltage	d2.0 ~ d255V	d12.0
1-05	Minimum output freq.	d1.0 ~ d60.0Hz	d1.0
1-06	Minimum output voltage	d2.0 ~ d255V	d12.0
1-07	Upper bound of freq.	d1 ~ d110%	d100
1-08	Lower bound of freq.	d0 ~ d100%	d0.0
1-09	Accel time 1 (Tacc1)	d0.1 ~ d600 Sec	d10.0
1-10	Decel time 1 (Tdec1)	d0.1 ~ d600 Sec	d10.0
1-11	Accel time 2	d0.1 ~ d600 Sec	d10.0
1-12	Decel time 2	d0.1 ~ d600 Sec	d10.0
1-13	JOG Accel time	d0.1 ~ d600 Sec	d10.0
1-14	JOG Decel time	d0.0 ~ d600 Sec	d10.0
1-15	JOG frequency	d1.0Hz~d400Hz	d6.0
1-16	Auto-accel/deccl	d0: Linear Accel/Deccl d1: Auto accel, linear deccl d2: Linear accel, auto deccl, d3: Auto Accel/Deccl d4: Linear accel. Auto deccl, stall prevention during deceleration d5: Auto accel. Auto deccl, stall prevention during deceleration	d0
1-17	S-curve setting in acceleration	d0 ~ d7	d0
1-18	S-curve setting in deceleration	d0 ~ d7	d0

Group 2: Operation Method Parameters

Pr.	Functions	Settings	Factory Setting
2-00	Source of frequency command	d0: Digital keypad d1: 0 ~ 10V from AVI d2: 4 ~ 20mA from AVI d3: Controlled by V.R on drive d4: RS-485 communication interface	d0
2-01	Source of operation command	d0: By digital keypad d1: By external terminals, keypad STOP enable d2: By external terminals, keypad d3: By RS-485 communication interface, keypad STOP enable d4: By RS-485 communication interface, keypad STOP disable	d0
2-02	Stop method	d0: Ramp stop d1: Coast stop	d0
2-03	Carrier freq.	d3 ~ d10K Hz	d10

Pr.	Functions	Settings	Factory Setting
2-04	Reverse operation inhibit	d0: Enable reverse d1: Disable reverse d2: Disable forward	d0
2-05	ACI (4 ~ 20mA) input loss detection	d0: Decel to 0Hz d1: Stop immediately, display EF d2: Run with the last freq.	d0
2-06	Line Start Lockout	d0: Enable d1: Disable	d0

Group 3: Output Function Parameters

Pr.	Functions	Settings	Factory Setting
3-00	Desired freq. attained	d1.0 ~ d400 Hz	d1.0
3-01	Terminal count value	d0 ~ d999	d0
3-02	Preliminary count value	d0 ~ d999	d0
3-03	Multi-function (relay output)	d0: not used d1: AC drive operational d2: Max. Output Freq. Attained d3: Zero Speed d4: Over Torque d5: Base-Block (B.B.) d6: Low Voltage Detection d7: AC Drive Operation Mode d8: Fault Indication d9: Desired Freq. Attained d10: PLC Program Running d11: PLC Program Step Complete d12: PLC Program Complete d13: PLC Program Operation Pause d14: Terminal Count Value Attained d15: Preliminary Count Value Attained d16: Ready State Indicator	d8

Group 4: Input Function Parameters

Pr.	Functions	Settings	Factory setting
4-00	Potentiometer bias freq.	d0.0~d350Hz	d0.0
4-01	Potentiometer bias polarity	d0: positive bias d1: negative bias	d0
4-02	Potentiometer freq. gain	d1~d200%	d100
4-03	Potentiometer reverse motion enable	d0: not used d1: reverse motion enable d2: forward motion only	d0
4-04	Multi-function input terminal1 (M1) (d 0~d 20)	d0: not used d1: M0: FWD/STOP, M1: REV/STOP d2: M0: RUN/STOP, M1: FWD/REV d3: M0, M1, M2: 3-wire operation control mode	d1
4-05	Multi-function input terminal 2(M2)	d4: External fault, normally open (N.O.) d5: External fault, normally closed (N.C.) d6: RESET d7: multi-step speed command 1 d8: multi-step speed command 2 d9: jog operation d10: accel/decel speed inhibit d11: first or second accel/decel time selection	d6
4-06	Multi-function input terminal 3(M3) (d 0, d 4~d 20)	d12: base-block (B.B.),normally open (N.O.) d13: base-block (B.B.),normally closed (N.C.) d14: increase master freq. d15: decrease master freq. d16: run PLC program d17: pause PLC d18: counter trigger signal d19: counter reset d20: select ACI/deselect AVI	d7

Group 5: Multi-step Speed and PLC Parameters

Pr.	Functions	Settings	Factory Setting
5-00	1 st step speed freq.	d0.0 ~ d400Hz	d0.0
5-01	2 nd step speed freq.	d0.0 ~ d400Hz	d0.0
5-02	3 rd step speed freq.	d0.0 ~ d400Hz	d0.0
5-03	PLC mode	d0: Disable PLC operation d1: Execute one program cycle d2: Continuously execute program cycles d3: Execute one program cycle step by step (separate by STOP) d4: Continuously execute one program cycle step by step (separate by STOP)	d0
5-04	PLC forward/reverse motion	d0 ~ d15 (d0: Forward, d1: Reverse)	d0
5-05	Time duration step 0	d0 ~ d65500 Sec	d0
5-06	Time duration step 1	d0 ~ d65500 Sec	d0
5-07	Time duration step 2	d0 ~ d65500 Sec	d0
5-08	Time duration step 3	d0 ~ d65500 Sec	d0

Group 6: Protection Parameters

Pr.	Functions	Settings	Factory Setting
6-00	Over-Voltage Prevention Level	d0:disable d350~d410V	d390

Pr.	Functions	Settings	Factory Setting
6-01	Over-current Prevention Level	d0: disable d20~d200%	d170
6-02	Over-torque detection	d0:disable d1:enabled during constant speed operation and continues until the continuous limit is reached. d2:enabled during constant speed operation and halted after detection. d3:enabled during accel and continues before continuous output time limit is reached. d4:enabled during accel and halted after over-torque detection.	d0
6-03	Over-torque detection level	d30 ~ d200%	d150
6-04	Over-torque detection time	d0.1 ~ d10.0 Sec	d0.1
6-05	Electronic thermal overload relay	d0: Not used d1: Act with standard motor d2: Act with special motor	d0
6-06	Electronic thermal characteristic	d30~d600 Sec	d60
6-07	Present fault record	d0: No fault occurred	d0
6-08	Second most recent fault record	d1: oc (over current) d2: ov (over voltage) d3: oH (over heat) d4: oL (over load)	
6-09	Third most recent fault record	d5: oL1 (electronic thermal) d6: EF (external fault) d7: Reserved	
6-10	Forth most recent fault record	d8: Reserved d9: oCA (current exceed during acceleration) d10: ocd (current exceed during deceleration) d11: ocn (current exceed during steady state)	
6-11	Fifth most recent fault record		
6-12	Sixth most recent fault record		

Group 7: Motor Parameters

Pr.	Functions	Settings	Factory Setting
7-00	Motor rated current	d30~d120 %	d85
7-01	Motor no-load current	d0 ~ d90 %	d50
7-02	Torque compensation	d0 ~ d10	d1
7-03	Slip compensation	d0.0 ~ d10.0	d0.0

Group 8: Special Parameters

Pr.	Functions	Settings	Factory Setting
8-00	DC braking voltage level	d0 ~ d30%	d0
8-01	DC braking time during start-up	d0.0 ~ d60.0 Sec	d0.0
8-02	DC braking time during stopping	d0.0 ~ d60.0 Sec	d0.0
8-03	Start-point for DC braking	d0.0 ~ d400.0 Sec	d0.0
8-04	Momentary power loss	d0: Stop operation after momentary power loss. d1: Continues after momentary power loss, speed search starts with master freq. d2: Continues after momentary power loss, speed search starts with min. output freq.	d0
8-05	Max. allowable power loss time	d0.3 ~ d5.0 Sec	d2.0
8-06	B.B. time for speed search	d0.3~d5.0 Sec	d0.5
8-07	Max. speed search current level	d30~d200%	d150
8-08	Skip freq. 1 upper bound	d0.0~d400 Hz	d0.0
8-09	Skip freq. 1 lower bound	d0.0~d400 Hz	d0.0
8-10	Skip freq. 2 upper bound	d0.0~d400 Hz	d0.0
8-11	Skip freq. 2 lower bound	d0.0~d400 Hz	d0.0
8-12	Skip freq. 3 upper bound	d0.0~d400 Hz	d0.0
8-13	Skip freq. 3 lower bound	d0.0~d400 Hz	d0.0
8-14	Auto restart after fault	d0~d10	d0
8-15	AVR function	d0: AVR function enable d1: AVR function disable d2: AVR function disable when decel	d2
8-16	Dynamic braking voltage	d350 ~ d450V	d380
8-17	DC braking lower bound limit	d0.0 ~ d400 Hz	d0.0

Group 9: Communication Parameters

Pr.	Functions	Settings	Factory Setting
9-00	Communication address	d1 ~ d247	d1
9-01	Transmission speed	d0: Baud rate 4800 d1: Baud rate 9600 d2: Baud rate 19200	d1
9-02	Transmission fault treatment	d0: Warn and continue running d1: Warn and ramp to stop d2: Warn and coasting stop d3: No warn and keep running	d0
9-03	Modbus communication watchdog timer	d0: Disable d1~d20: 1 ~ 20 Sec	d0

Pr.	Functions	Settings	Factory Setting
9-04	Communication protocol	ASCII mode d0: 7,N,2 d1: 7,E,1 d2: 7,O,1 d3: 8,N,2 RTU mode d4: 8,E,1 d5: 8,O,1 d6: 8,N,2 d7: 8,E,1 d8: 8,O,1	d0

5 Troubleshooting and Fault Information

The VFD-L AC drive has a comprehensive fault diagnostic system that includes several different alarms and fault messages. Once a fault is detected, the corresponding protective functions will be activated. The following faults are displayed on the AC drive digital keypad. The six most recent faults can be read on the digital keypad display by viewing Pr.6-07 to Pr.6-12. NOTE: faults can be cleared by pressing the Reset key on the keypad or Input Terminal.

Common Problems and Solutions

Fault Name	Fault Descriptions	Corrective Actions
OL	The AC drive detects an abnormal increase in current.	1. Check whether the motors horsepower corresponds to the AC drive output power. 2. Check the wiring connections between the AC drive and motor for possible short circuits. 3. Increase the Acceleration time (Pr.1-09, Pr.1-11). 4. Check for possible excessive loading conditions at the motor. 5. If there are any abnormal conditions when operating the AC drive after the short-circuit is removed, the drive should be sent back to manufacturer.
OU	The AC drive detects that the DC bus voltage has exceeded its maximum allowable value.	1. Check whether the input voltage falls within the rated AC drive input voltage. 2. Check for possible voltage transients. 3. Bus over-voltage may also be caused by motor regeneration. Increase the decel time.
OH	The AC drive temperature sensor detects excessive heat.	1. Ensure that the ambient temperature falls within the specified temperature range. 2. Make sure that the ventilation holes are not obstructed. 3. Remove any foreign objects on the heat sink and check for possible dirty heat-sink fins. 4. Provide enough spacing for adequate ventilation.
UV	The AC drive detects that the DC bus voltage has fallen below its minimum value.	Check whether the input voltage falls within the rated AC drive's input voltage.
OLI	Internal electronic overload trip	1. Check for possible motor overload. 2. Check electronic thermal overload setting. 3. Increase motor capacity. 4. Reduce the current level so that the drive output current does not exceed the value set by the Motor Rated Current Pr.7-00.
EF	The external terminal EF-GND goes from OFF to ON.	When external terminal EF-GND is closed, the output will be turned off. (under N.Q.E.F.)
OL2	Motor overload. Check the parameter settings (Pr.6-03 to Pr.6-05)	1. Reduce the motor load. 2. Adjust the over-torque detection setting to an appropriate setting.
OCF	Over-current during acceleration: 1. Short-circuit at motor output. 2. Torque boost too high. 3. Acceleration time too short. 4. AC drive output capacity is too small.	1. Check for possible poor insulation at the output line. 2. Decrease the torque boost setting in Pr.7-02. 3. Increase the acceleration time. 4. Replace with the AC drive with one that has a higher output capacity (next HP size).
OCd	Over-current during deceleration: 1. Short-circuit at motor output. 2. Deceleration time too short. 3. AC drive output capacity is too small.	1. Check for possible poor insulation at the output line. 2. Increase the deceleration time. 3. Replace with the AC drive with one that has a higher output capacity (next HP size).
OB	External Base Block. AC drive output is turned off.	1. When the external input terminal (B.B) is active, the AC drive output will be turned off. 2. Disable this connection and the AC drive will begin to work again.
OCn	Over-current during steady state operation: 1. Short-circuit at motor output. 2. Sudden increase in motor loading. 3. AC drive output capacity is too small.	1. Check for possible poor insulation at the output line. 2. Check for possible motor stall. 3. Replace with the AC drive with one that has a higher output capacity (next HP size).

Fault Name	Fault Descriptions	Corrective Actions
FI	Internal memory IC can not be programmed.	1. Switch off power supply. 2. Check whether the input voltage falls within the rated AC drive input voltage. 3. Switch the AC drive back on.
F2	Internal memory IC can not be read.	1. Check the connections between the main control board and the power board. 2. Reset drive to factory defaults.
F3	Drive's internal circuitry abnormal.	1. Switch off power supply. 2. Check whether the input voltage falls within the rated AC drive input voltage. Switch on the AC drive.
FA	Auto accel/decel failure	Don't use the function of auto acceleration/ deceleration.
HPF	Hardware protection failure	Return to the factory.
codE	Software protection failure	Return to the factory.
EI	Communication Error	1. Check the connection between the AC drive and computer for loose wires. 2. Check if the communication protocol is properly set.
OL	The AC drive detects excessive drive output current.	1. Check whether the motor is overloaded. 2. Reduce torque compensation setting as set in Pr.7-02. 3. Increase the AC drive's output capacity. Note: The AC drive can withstand up to 150% of the rated current for a maximum of 60 seconds.

6 Standard Specifications

Voltage Class	115V			230V		
	Model Number VFD-XXXLXXA/B	002	004	002	004	007
Applicable Motor Output (kW)	0.2	0.4	0.2	0.4	0.7	1.5
Rated Output Capacity (KVA)	0.6	1.0	0.6	1.0	1.6	2.7
Rated Output Current (A)	1.6	2.5	1.6	2.5	4.2	7.0
Max. Output Voltage (V)	3-phase corresponds to double input voltage			Three-phase corresponds to input voltage		
Rated Frequency (Hz)	1.0~400Hz					
Rated Input Current (A)	6	9	4.9/1.9	6.5/2.7	9.7/5.1	★/9
Input voltage Tolerance	Single phase 90~132V 50/60Hz		Single / 3-phase 180~264V 50/60Hz		3-phase 180~264V 50/60Hz	
Frequency tolerance	±5%					
Control system	SVPWM (Sinusoidal Pulse Width Modulation, carried frequency 3kHz~10kHz)					
Output Frequency Resolution	0.1Hz					
Torque Characteristics	Including the auto-torque, auto-slip compensation, starting torque can be 150% at 5 Hz					
Overload Endurance	150% of rated current for 1 minute					
Accel/Decel Time	0.1~600Sec. (can be set individually)					
V/F pattern	V/F pattern adjustable					
Stall Prevention Level	20~200%, setting of Rated Current					
Operating Characteristics	Frequency Setting	Keypad	Setting by ▲▼ Keys or V/R			
		External Signal	Potentiometer-5KΩ/0.5W, DC 0 ~ +10V (input impedance 47KΩ), 4~20mA (output impedance 250Ω), multi-function inputs 1 to 3 (3steps, JOG, UP/DOWN command), communication setting			
	Operation Setting	Keypad	Setting by RUN/STOP keys			
Signal	External Signal	M0,M1,M2,M3 can be combined to offer various modes of operation, RS-485 communication port				
	Multi-function Input Signal	Multi-step selection 0 to 3, Jog, accel/decel inhibit, first/second accel/decel switch, counter, PLC Operation, external Base Block (NC,NO) selection				
Multi-function Output Signal	AC Drive Operating, Frequency Attained, Non-zero speed, Base Block, Fault Indication, Local/Remote indication, PLC Operation indication.					
Other Function	AVR, S-curve, Over-Voltage Stall Prevention, DC Braking, Fault Records, Adjustable Carried Frequency, Starting Frequency Setting of DC Braking, Over-Current Stall Prevention, Momentary Power Loss restart, Reverse Inhibition, Frequency Limits, Parameter Lock/Reset					
Protection	Over Voltage, Over Current, Under Voltage, Overload, Electronic thermal, Overheating, Self-testing					
Other	Including EMI Filter					
Cooling	Forced air-cooling					
Environment	Installation Location	Altitude 1,000 m or below, keep from corrosive gasses, liquid and dust				
	Ambient Temperature	-10°C~40°C (Non-Condensing and not frozen)				
	Storage Temperature	-20°C to 60°C				
	Ambient Humidity	Below 90%RH (non-condensing)				
Vibration	9.80665m/s ² (1G) less than 20Hz, 5.88m/s ² (0.6G) at 20 to 50Hz					